

# 穴用C型止め輪(スナップリング)

**HASHIMA**

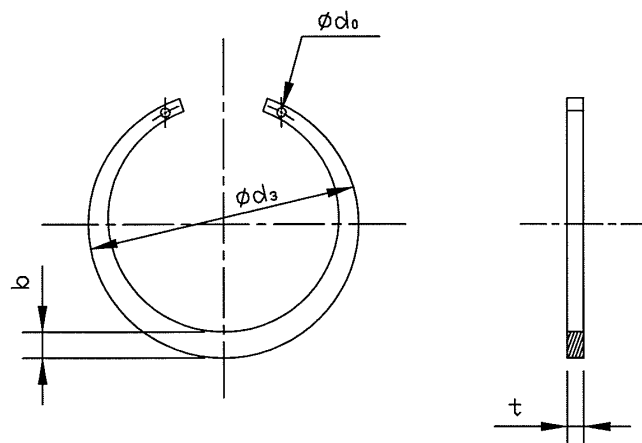

単位:mm

| 呼び径 |     | 止 め 輪 寸 法 |               |    |           |    |       |
|-----|-----|-----------|---------------|----|-----------|----|-------|
|     |     | $d_3$     |               | t  |           | b  | $d_0$ |
|     |     | 寸法        | 公差            | 寸法 | 公差        | 約  | 最小    |
| R-  | 310 | 327       | +1.80<br>-0.9 | 6  | $\pm 0.2$ | 17 | 5     |
|     | 320 | 337       |               |    |           | 17 |       |
|     | 330 | 347       |               |    |           | 18 |       |
|     | 340 | 357       |               |    |           | 18 |       |
|     | 350 | 367       |               |    |           | 19 |       |
|     | 360 | 377       |               |    |           | 19 |       |
|     | 370 | 387       |               |    |           | 19 |       |
|     | 380 | 397       |               |    |           | 19 |       |
|     | 390 | 407       |               |    |           | 19 |       |
|     | 400 | 417       |               |    |           | 19 |       |
|     | 410 | 430       | +2.0<br>-1.0  | 7  |           | 23 | 6     |
|     | 420 | 440       |               |    |           | 23 |       |
|     | 430 | 450       |               |    |           | 23 |       |
|     | 440 | 460       |               |    |           | 23 |       |
|     | 450 | 470       |               |    |           | 23 |       |
|     | 460 | 480       |               |    |           | 24 |       |
|     | 470 | 490       |               |    |           | 24 |       |
|     | 480 | 500       |               |    |           | 24 |       |
|     | 490 | 510       |               |    |           | 24 |       |
|     | 500 | 520       |               |    |           | 24 |       |
|     | 510 | 535       | +3.0<br>-1.5  | 8  |           | 25 | 6     |
|     | 520 | 545       |               |    |           | 25 |       |
|     | 530 | 555       |               |    |           | 25 |       |
|     | 540 | 565       |               |    |           | 25 |       |
|     | 550 | 575       |               |    |           | 25 |       |
|     | 560 | 585       |               |    |           | 26 |       |
|     | 570 | 595       |               |    |           | 26 |       |
|     | 580 | 605       |               |    |           | 26 |       |
|     | 590 | 615       |               |    |           | 26 |       |
|     | 600 | 625       |               |    |           | 26 |       |

上記品は、受注生産品です。