

穴用同心トメワ AR BR

HASHIMA

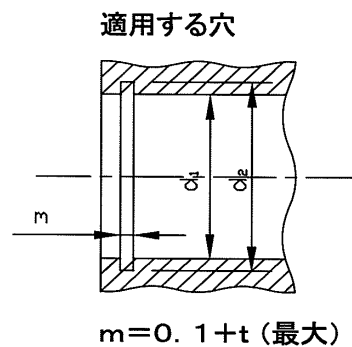
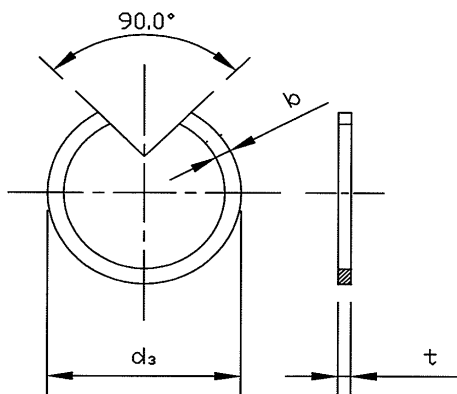

$$m = 0.1 + t \text{ (最大)}$$

単位: mm

呼び径	止 め 輪 寸 法						d ₂ 寸法	
	d ₁	d ₃	b		t			
	寸法	最小	寸法	公差	寸法	公差		
AR BR - 7	7	7.5	1.0	±0.08	0.8	±0.06	7.3	
8	8	8.5					8.3	
9	9	9.5					9.3	
10	10	10.6					10.4	
11	11	11.6	1.3		1.0		11.4	
12	12	12.7					12.4	
13	13	13.8					13.5	
14	14	14.8					14.5	
15	15	15.8	1.6		±0.06		15.5	
16	16	16.8					16.5	
17	17	17.8					17.5	
18	18	18.9					18.5	
19	19	19.9	1.75				1.2	19.6
20	20	21.0						20.6
21	21	22.0						21.6
22	22	23.0						22.6
23	23	24.0	1.75				1.2	23.6
24	24	25.2						24.8
25	25	26.2						25.8
26	26	27.2						26.8
27	27	28.2	2.3				1.5	27.8
28	28	29.2						28.8
29	29	30.2						29.8
30	30	31.4						31.0
31	31	32.4	2.3				1.5	32.0
32	32	33.4						33.0
33	33	34.4						34.0
34	34	35.4						35.0
35	35	36.4	2.3				1.5	36.0
36	36	37.8						37.2
37	37	38.8						38.2
38	38	39.8						39.2
39	39	40.8	2.3				1.5	40.2
40	40	41.8						41.2
41	41	42.8						42.2
42	42	43.8						43.2
43	43	44.8	2.3				1.5	44.2
44	44	45.8						45.2
45	45	46.8						46.2
46	46	47.8						47.2
47	47	48.8	2.3				1.5	48.2
48	48	49.8						49.2

穴用同心トメワ AR BR

HASHIMA

単位: mm

呼び径	止 め 輪 寸 法						d ₂ 寸法
	d ₁	d ₃	b		t		
	寸法	最小	寸法	公差	寸法	公差	
AR BR - 49	49	50.8	2.3		1.5		50.2
50	50	51.8					51.2
52	52	54.3					53.5
53	53	55.3					54.5
54	54	56.3					55.5
55	55	57.3					56.5
57	57	59.3					58.5
58	58	60.3					59.5
60	60	62.3					61.5
61	61	63.3					62.5
62	62	64.3					63.5
63	63	65.3					64.5
64	64	66.3					65.5
65	65	67.3					66.5
66	66	68.3	67.5				
68	68	70.3	69.5				
70	70	72.3	71.5				
72	72	74.6	73.8				
73	73	75.6	74.8				
74	74	76.6	75.8				
75	75	77.6	76.8				
76	76	78.6	77.8				
77	77	79.6	78.8				
78	78	80.6	79.8				
79	79	81.6	80.8				
80	80	82.6	81.8				
81	81	83.6	82.8				
82	82	84.6	83.8				
83	83	85.6	84.8				
85	85	87.6	86.8				
86	86	88.6	87.8				
88	88	91.0	90.0				
90	90	93.0	92.0				
92	92	95.0	94.0				
93	93	96.0	95.0				
95	95	98.0	97.0				
97	97	100.0	99.0				
98	98	101.0	100.0				
100	100	103.0	102.0				
102	102	105.3	104.3				
103	103	106.3	105.3				
105	105	108.3	107.3				
107	107	110.3	109.3				
108	108	111.3	110.3				
110	110	113.3	112.3				
112	112	115.3	114.3				
113	113	116.3	115.3				
115	115	118.3	117.3				
117	117	120.3	119.3				
118	118	121.3	120.3				
120	120	123.3	122.3				
123	123	126.3	125.3				
125	125	128.3	127.3				
127	127	130.3	129.3				
130	130	133.3	132.3				

穴用同心トメワ AR BR

HASHIMA

単位: mm

呼び径	止 め 輪 寸 法						d ₂ 寸法
	d ₁	d ₃	b		t		
	寸法	最小	寸法	公差	寸法	公差	
AR BR - 133	133	136.3	3.4				135.3
135	135	138.3					137.3
137	137	140.3					139.3
140	140	143.6					142.6
143	143	146.6					145.6
145	145	148.6					147.6
150	150	153.6	4.0		2.5		152.6
153	153	156.6					155.6
160	160	163.6					162.6
163	163	166.6					165.6
165	165	168.6					167.6
170	170	173.6					172.6
173	173	176.6					175.6
175	175	178.6					177.6
180	180	183.6					182.6
183	183	186.6					185.6
190	190	194.5	5.0	±0.08	3.0	±0.06	193.0
195	195	199.5					198.0
200	200	204.5					203.0
205	205	209.5					208.0
210	210	214.5					213.0
215	215	219.5					218.0
220	220	224.5					223.0
225	225	229.5					228.0
230	230	234.5					233.0
235	235	239.5					238.0
240	240	244.5	7.5		4.0		243.0
250	250	254.5					253.0
260	260	267.0					265.0
270	270	277.0					275.0
280	280	287.0					285.0
300	300	307.0					305.0
320	320	327.0					325.0
325	325	332.0					330.0
350	350	357.0					355.0
355	355	362.0					360.0
360	360	367.0	365.0				
375	375	382.0	380.0				
380	380	387.0	385.0				
385	385	392.0	390.0				
395	395	402.0	400.0				
400	400	407.0	405.0				
415	415	422.0	420.0				
420	420	427.0	425.0				
440	440	447.0	445.0				

材質:ばね用鋼 硬さ:40~50HRC 表面処理:TC(テンパーカー)