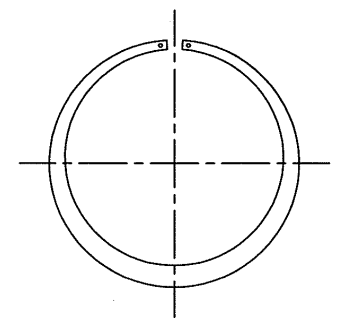
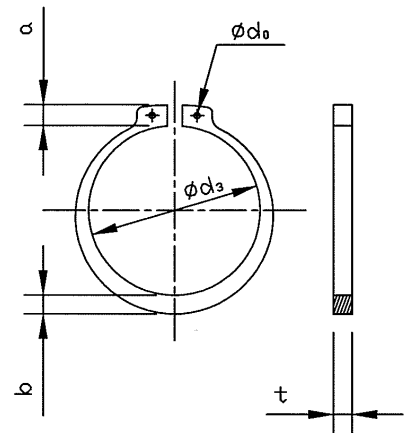

軸用C型止め輪(スナップリング)【JIS B 2804】

HASHIMA

単位:mm

呼び径	止 め 輪 寸 法								
	d_3		t		b	a	d_0 最小		
	寸法	公差	寸法	公差	約	約			
S-50	45.8	± 0.40	2.0	±0.07	5.0	6.7	2.5		
55	50.8	± 0.45			2.5	±0.08		5.0	7.0
60	55.8							5.5	7.2
65	60.8		6.4	7.4					
68	63.5		6.4	7.8					
70	65.5		6.4	7.8					
72	67.5		7.0	7.9					
75	70.5		7.0	7.9					
78	73.5		7.4	8.1					
80	74.5		7.4	8.2					
82	76.5		7.4	8.3			3.0		
85	79.5	± 0.55	3.0	±0.09	8.0	8.4			
88	82.5				8.0	8.6			
90	84.5				8.0	8.7			
95	89.5				8.6	9.1			
100	94.5				9.0	9.5			
105	98.0				9.5	9.8			
110	103.0				9.5	10.0			
115	108.0				9.5	10.5			
120	113.0				10.3	10.9			
125	118.0				10.3	11.3	4.0		
130	123.0	+ 0.63 - 1.26	4.0	±0.09	11.0	11.5			
135	128.0				11.0	11.5			
140	133.0				11.0	11.8			
145	138.0				11.6	11.8			
150	142.0				11.6	12.3			
155	146.0				12.2	12.7			
160	151.0				12.2	12.9			
165	155.5				12.9	13.1			
170	160.5				12.9				
175	165.5				12.9		4.0		
180	170.5	13.5							
185	175.5	13.5							
190	180.5	14.0							
195	185.5	14.0							
200	190.5	14.0							
205	193.0	14.0							
210	198.0	14.0							
215	203.0	14.0							
220	208.0	14.0							
225	213.0	14.0							
230	218.0	14.0							
235	223.0	14.0							
240	228.0	+ 0.72 - 1.44	5.0	±0.15	14.0				
245	233.0				14.0				
250	238.0				14.0				
260	245.0				16.0				
270	255.0				16.0				
280	265.0				16.0				
290	275.0				16.0				
300	285.0				16.0				

 呼び径170^m/_m以上